

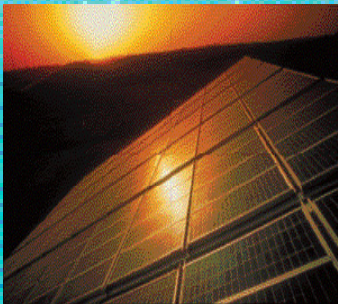

Radiantmax Floor Heating

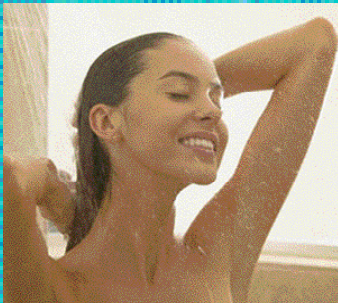

Solar Hydronic



Tankless Hot Water

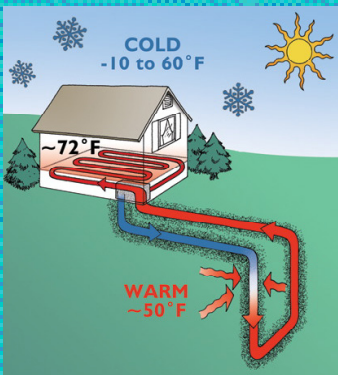

Geothermal



- Low cost
- ASTM certified
- Oxygen barrier
- Designed to last more than a lifetime
- For potable plumbing applications as well
- 25 year warranty
- Decades of proven performance
- Durable & flexible

RADIANTMAX BPEX TUBING offers comfort and efficiency with our radiant heating systems and when used for potable water systems. When integrated into our radiant heating designs, radiant heating is very simply the most comfortable type of space heating available. Our systems range from residential systems to more demanding applications like garages, industrial buildings, airplane hangars, car washes, snowmelting and many other applications. The hot water residential system is ideal for new construction or retrofits and can be used for whole house heating.

When used for potable water, there are enormous cost savings in both time and materials. Radiantmax BPEX offers a fast and flexible plumbing solution.

Radiantmax BPEX tubing is the brand that is built to last. The superior quality and reliability of Radiantmax BPEX tubing with an oxygen barrier starts at the molecular level. "Cross linking" creates bonds between individual molecular strands, resulting in a tube with maximum temperature and chemical resistance as well as flexibility for ease of installation.

# Radiantmax BPEX Tubing

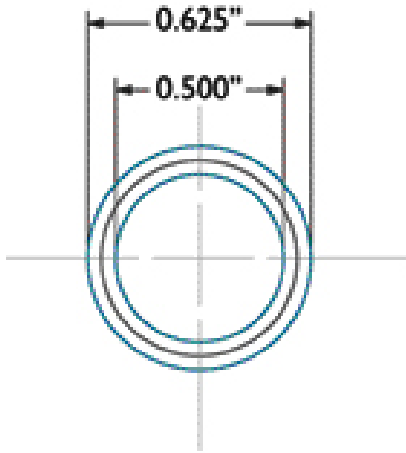

## Radiantmax BPEX tubing

- 1/2" standard sizing
- Radiant applications
- Domestic water applications

Diameter:	O.D. 0.625"
	I.D. 0.500"
Length:	300'
Crosslink Type	PEX type B
Performance Spec:	80PSI @ 200°F
	100PSI @ 180°F
Standards:	ASTM F1807/F2159/F2434/F876/F877
	CSA/B137.5 L24293 ICBO ES ER-5287
	PEX 1006 SDR-9 .070

Represented by:

**RADIANTMAX**  
Radiant Heating Systems

**585-412-4245**  
**[www.eagle-mt.com](http://www.eagle-mt.com)**